

CITY OF FORNEY, TEXAS

ORDINANCE NO. \_\_\_\_\_

**AN ORDINANCE OF THE CITY OF FORNEY, TEXAS, AMENDING CHAPTER 3 OF THE CODE OF ORDINANCES OF THE CITY OF FORNEY, TEXAS, BY AMENDING ARTICLE 3.02, DIVISION 5, "SWIMMING POOL AND HOT TUB CODE," ADOPTING THE 2021 EDITION OF THE *INTERNATIONAL SWIMMING POOL AND SPA CODE* BY THE AMENDMENT OF SECTION 3.02.501, "ADOPTION," AND ESTABLISHING AMENDMENTS TO THE 2021 EDITION OF THE *INTERNATIONAL SWIMMING POOL AND SPA CODE* IN ACCORDANCE WITH THE NORTH CENTRAL TEXAS COUNCIL OF GOVERNMENTS' RECOMMENDED AMENDMENTS, LOCAL AMENDMENTS AND INDUSTRY STANDARDS THROUGH THE ADDITION OF SECTION 3.02.202, "AMENDMENTS"; PROVIDING A PENALTY; REPEALING ALL CONFLICTING ORDINANCES; PROVIDING A SEVERABILITY CLAUSE; AND PROVIDING AN EFFECTIVE DATE.**

**WHEREAS**, the International Code Council ("ICC") has developed a set of comprehensive and coordinated national model construction codes (known as the "International Codes"), and the City of Forney, Texas ("City") has been involved throughout the development process of the International Codes, through the North Texas Chapter of the International Code Council and through the regional review process by the Regional Codes Coordinating Committee of the North Central Texas Council of Governments ("NCTCOG"); and

**WHEREAS**, the *International Swimming Pool and Spa Code* has been prepared by the ICC and in addition to review by the NCTCOG, has been reviewed by City staff; and

**WHEREAS**, the 2021 edition of the *International Swimming Pool and Spa Code* is intended to ensure public health, safety and welfare insofar as they are affected by the continued occupancy and maintenance of structures and premises; and

**WHEREAS**, the provisions of the 2021 edition of the *International Swimming Pool and Spa Code* will apply to all aquatic recreation facilities, pools and spas, and establish minimum requirements to safeguard health, safety, property and public welfare; and

**WHEREAS**, the provisions of the 2021 edition of the *International Swimming Pool and Spa Code* address the responsibility of owners and operators of aquatic recreation facilities, pool and spas, and provide for administration, enforcement and penalties for violations of said code; and

**WHEREAS**, the current Swimming Pool and Spa Code in the City is the 2000 edition of the *International Swimming Pool and Hot Tub Code*, and the City's Swimming Pool and Spa Code should be updated to the most current, published codes available; and

**WHEREAS**, the City Council of the City of Forney, Texas ("City Council") has determined that it is in the best interest of the citizens of the City of Forney to adopt the 2021 edition of the *International Swimming Pool and Spa Code*, as set forth herein and as that code is specifically modified by this Ordinance.

**NOW, THEREFORE, BE IT ORDAINED BY THE CITY COUNCIL OF THE CITY OF FORNEY, TEXAS, THAT:**

**Section 1. FINDINGS INCORPORATED**

All of the above premises are found to be true and correct factual and legislative determinations of the City of Forney and are hereby approved and incorporated into the body of this Ordinance as if copied in their entirety.

**Section 2. AMENDMENT OF ORDINANCE**

From and after the effective date of this Ordinance, Chapter 3, Article 3.02, Division 5, of the Code of Ordinances of the City of Forney, Texas, entitled "Swimming Pool and Spa Code," is hereby amended by amending Sections 3.02.201, entitled "Adoption," and 3.02.202, entitled "Amendments," in their entirety and replacing said provisions with new Sections 3.02.201, entitled "Adoption of *International Swimming Pool and Spa Code*," and 3.02.202, entitled "*International Swimming Pool and Spa Code* Amendments," to read as follows:

**"Sec. 3.02.201 Adoption of *International Swimming Pool and Spa Code*.**

The *International Swimming Pool and Spa Code*, 2021 edition, a copy of which is on file in the offices of the City of Forney, is hereby adopted and designated as the Swimming Pool and Spa Code of the City, the same as though the provisions of the *International Swimming Pool and Spa Code*, 2021 edition, were copied at length in this section, subject to the deletions, amendments, and additions provided in section 3.02.202.

**Sec. 3.02.202 *International Swimming Pool and Spa Code* Amendments.**

The following amendments repeal and reenact or add sections to the *International Swimming Pool and Spa Code*, 2021 edition, adopted by Section 3.02.201 of this Code for the purpose of consistency with specific past practices and the recommendations of the North Central Texas Council of Governments, and all sections not expressly amended remain in full force and effect as adopted.

- (1) Section 101.1 of the *International Swimming Pool and Spa Code*, 2021 edition, is hereby amended to read as follows:

**101.1 Title.** These regulations shall be known as the Swimming Pool and Spa Code for the City of Forney and shall be cited as such. It is referred to herein as the "this code."

- (2) Section 102.9 of the *International Swimming Pool and Spa Code*, 2021 edition, is hereby amended to read as follows:

**102.9 Other laws.** The provisions of this code shall not be deemed to nullify any provisions of local, state or federal law, to include but not limited to:

1. Texas Department of State Health Services (TDSHS); Standards for Public Pools and Spas; §285.181 through §285.208, (TDSHS rules do not apply to pools serving one- and two-family dwellings or townhouses).

2. Texas Department of Licensing and Regulation (TDLR); 2012 Texas Accessibility Standards (TAS), TAS provide the scoping and technical requirements for accessibility for Swimming Pool, wading pools and spas and shall comply with 2012 TAS, Section 242. (TAS rules do not apply to pools serving one- and two-family dwellings or townhouses).

**Exception:** Elements regulated under Texas Department of Licensing and Regulation (TDLR) and built in accordance with TDLR approved plans, including any variances or waivers granted by the TDLR, shall be deemed to be in compliance with the requirements of this Chapter.

- (3) Section 113.4, Violation penalties, of the *International Swimming Pool and Spa Code*, 2021 edition, is hereby amended to read as follows:

**113.4 Violation penalties.** Any person who shall violate a provision of this code or shall fail to comply with any of the requirements thereof or who shall erect, install, alter or repair a pool or spa in violation of the approved construction documents or directive of the code official, or of a permit or certificate issued under the provisions of this code may be punishable for each day of the violation set forth by the authority having jurisdiction. ~~, shall be guilty of a [SPECIFY OFFENSE], punishable by a fine of not more than [AMOUNT] dollars or by imprisonment not exceeding [NUMBER OF DAYS], or both such a fine and imprisonment. Each day that a violation continues after due notice has been served shall be deemed a separate offense.~~

- (4) Section 305 of the *International Swimming Pool and Spa Code*, 2021 edition, is hereby amended to read as follows:

**305.1 General.** The provisions of this section shall apply to the design of barriers for restricting entry into areas having pools and spas. In only one-and two-family dwellings and townhouses, where spas or hot tubs are equipped with a lockable safety cover complying with ASTM F1346 and swimming pools are equipped with a powered safety cover that complies with ASTM F1346, the areas where those spas, hot tubs or pools are located shall not be required to comply with Sections 305.2 through 305.7.

- (5) Section 305.4, Structure wall as a barrier, of the *International Swimming Pool and Spa Code*, 2021 edition, is hereby amended to read as follows:

**305.4 Structure wall as a barrier.** Where a wall of a dwelling or structure of a one- and two-family dwelling or townhouse or its accessory structure serves as part of a barrier and where doors or windows provide direct access to the pool or spa through that wall, one of the following shall be required:

1. Remainder unchanged
2. Remainder unchanged
3. Remainder unchanged
4. Remainder unchanged
5. Remainder unchanged
6. Remainder unchanged

- (6) Section 305.6 of the *International Swimming Pool and Spa Code*, 2021 edition, is hereby amended to read as follows:

**305.6 Natural barriers used in a one- and two-family dwelling or townhouse.**

In the case where the pool or spa area abuts the edge of a lake or other natural body of water, public access is not permitted or allowed along the shoreline, and required barriers extend to and beyond the water’s edge a minimum of eighteen (18) inches, a barrier is not required between the natural body of water shoreline and the pool or spa.

- (7) Section 307.1.4, Accessibility, of the *International Swimming Pool and Spa Code*, 2021 edition, is hereby amended to add an exception to read as follows:

**Exception:** Components of projects regulated by and registered with Architectural Barriers Division of Texas Department of Licensing and Regulation shall be deemed to be in compliance with the requirements of this chapter.

- (8) Section 307.2.2.2 of the *International Swimming Pool and Spa Code*, 2021 edition, is hereby added to read as follows:

**307.2.2.2 Adjacency to Structural Foundation.** Depth of the swimming pool and spa shall maintain a ratio of 1:1 from the nearest building foundation or footing of a retaining wall.

**Exception:** A sealed engineered design drawing of the proposed new structure shall be submitted for approval.

- (9) Section 310 of the *International Swimming Pool and Spa Code*, 2021 edition, is hereby amended to read as follows:

**310.1 General.** Suction entrapment avoidance for pools and spas shall be provided in accordance with APSP 7 (ANSI/PHTA/ICC 7) or for public swimming pools in accordance with State of Texas Rules for Public Swimming Pools and Spas, Title 25 TAC Chapter 265 Subchapter L, Rule §265.190.

- (10) Section 402.12 of the *International Swimming Pool and Spa Code*, 2021 edition, is hereby amended to read as follows:

**402.12 Water envelopes.** The minimum diving water envelopes shall be in accordance with ~~Table 402.12~~ Texas department of State Health services, Administrative Code Title 25, Chapter 265, Section 186 (e) and Figure: 25 TAC 256.186 (e) (6). (Delete Table 402.12 and Figure 402.12)

**ADD: Figure: 25 TAC §265.186 (e) (6)**

Maximum Diving Board Height Over Water	¾ Meter	1 Meter	3 Meters
Max. Diving Board Length	12 ft.	16 ft.	16 ft.
Minimum Diving Board Overhang	2 ft. 6 in.	5 ft.	5 ft.
D1 Minimum	8 ft. 6 in.	11 ft. 2 in.	12 ft. 2 in.
D2 Minimum	9 ft.	10 ft. 10 in.	11 ft. 10 in.
D3 Minimum	4 ft.	6 ft.	6 ft.

L1 Minimum	4 ft.	5 ft.	5 ft.
L2 Minimum	12 ft.	16 ft. 5 in.	19 ft. 9 in.
L3 Minimum	14 ft. 10 in.	13 ft. 2 in.	13 ft. 11 in.
L4 Minimum	30 ft. 10 in.	34 ft. 7 in.	38 ft. 8 in.
L5 Minimum	8 ft.	10 ft.	13 ft.
H Minimum	16 ft.	16 ft.	16 ft.
From Plumbet to Pool Wall at Side	9 ft.	10 ft.	11 ft. 6 in.
From Plumbet to Adjacent Plumbet	10 ft.	10 ft.	10 ft.

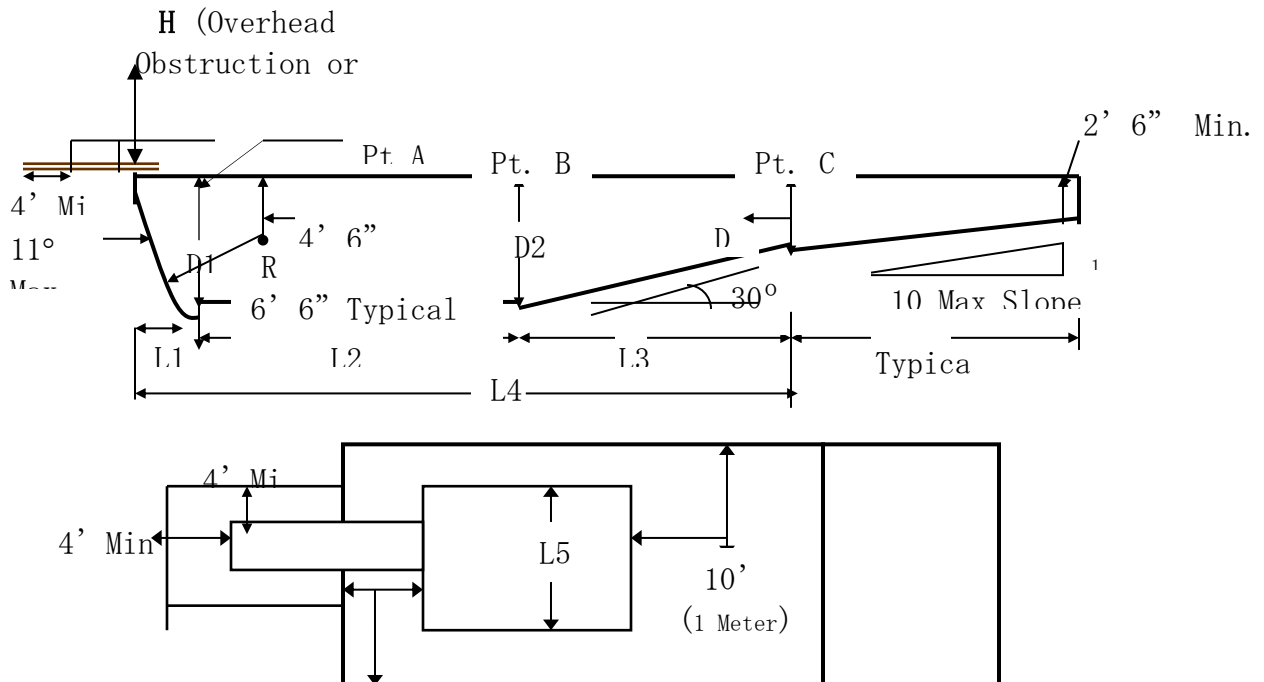

- (11) Sections 411.2.1 and 411.2.2 of the *International Swimming Pool and Spa Code*, 2021 edition, are hereby amended to read as follows:

**411.2.1 Tread dimensions and area.** Treads shall have a minimum unobstructed horizontal depth (i.e., horizontal run) of 12 inches and a minimum width of 20 inches. ~~not be less than 24 inches (607mm) at the leading edge. Treads shall have an unobstructed surface area of not less than 240 square inches (154838mm<sup>2</sup>) and an unobstructed horizontal depth of not less than 10 inches (254 mm) at the center line.~~

**411.2.2 Risers.** Risers for steps shall have a maximum uniform height of 10 inches, with the bottom riser height allowed to taper to zero. ~~except for the bottom riser, shall have a uniform height of not greater than 12 inches (305 mm) measured at the center line. The bottom riser height is allowed to vary to the floor.~~

- (12) Sections 411.5.1 and 411.5.2 of the *International Swimming Pool and Spa Code*, 2021 edition, are hereby amended to read as follows:

**411.5.1 Swimouts.** Swimouts, located in either the deep or shallow area of a pool, shall comply with all of the following:

1. Unchanged
2. Unchanged
3. Unchanged
4. The leading edge shall be visibly set apart and provided with a horizontal solid or broken stripe at least 1 inch wide on the top surface along the front leading edge of each step. This stripe shall be plainly visible to persons on the pool deck. The stripe shall be a contrasting color to the background on which it is applied, and the color shall be permanent in nature and shall be a slip-resistant surface.

**411.5.2 Underwater seats and benches.** Underwater seats and benches, whether used alone or in conjunction with pool stairs, shall comply with all of the following:

1. Unchanged
2. Unchanged
3. Unchanged
4. Unchanged
5. The leading edge shall be visually set apart and provided with a horizontal solid or broken stripe at least 1 inch wide on the top surface along the front leading edge of each step. This stripe shall be plainly visible to persons on the pool deck. The stripe shall be a contrasting color to the background on which it is applied, and the color shall be permanent in nature and shall be a slip-resistant surface.
6. Unchanged
7. Unchanged

- (13) Section 610.5.1 of the *International Swimming Pool and Spa Code*, 2021 edition, is hereby amended to read as follows:

**610.5.1 Uniform height of 10 inches.** Except for the bottom riser, risers at the centerline shall have a maximum uniform height of 10 inches (254 mm). The bottom riser height shall be permitted to vary from the other risers.

- (14) Section 804, Diving Water Envelopes, of the *International Swimming Pool and Spa Code*, 2021 edition, is hereby amended to read as follows:

**804.1 General.** The minimum diving water envelopes shall be in accordance with Table 804.1 and Figure 804.1, or the manufacturer's specifications, whichever is greater. Negative construction tolerances shall not be applied to the dimensions of the minimum diving water envelopes given in Table 804.1.

### **Section 3. PENALTY CLAUSE**

Any person, firm or corporation violating any of the provisions or terms of this Ordinance or the Code of Ordinances as amended hereby shall be deemed guilty of a misdemeanor, and upon conviction shall be punished by a fine not to exceed the sum of Two Thousand Dollars

(\$2,000.00) for each offense, and each and every day such violation shall continue shall constitute a separate offense.

**Section 4. SEVERABILITY CLAUSE**

It is hereby declared to be the intention of the City Council that the phrases, clauses, sentences, paragraphs and sections of this Ordinance are severable, and if any phrase, clause, sentence, paragraph or section of this Ordinance shall be declared unconstitutional by the valid judgment or decree of any court of competent jurisdiction, such unconstitutionality shall not affect any of the remaining phrases, clauses, sentences, paragraphs and sections of this Ordinance, since the same would have been enacted by the City Council without the incorporation of this Ordinance of any such unconstitutional phrase, clause, sentence, paragraph or section.

**Section 5. REPEALER CLAUSE**

Any provision of any prior ordinance of the City, whether codified or uncoded, which is in conflict with any provision of this Ordinance, is hereby repealed to the extent of the conflict, but all other provisions of the ordinances of the City, whether codified or uncoded, which are not in conflict with the provisions of this Ordinance shall remain in full force and effect.

**Section 6. EFFECTIVE DATE**

Upon its passage and publication as required by law, this Ordinance shall become effective on January 1, 2023.

**PASSED, APPROVED AND ADOPTED** by the City Council of the City of Forney, Texas, on this the \_\_\_\_\_ day of \_\_\_\_\_, 2022.

\_\_\_\_\_  
**Amanda Lewis, Mayor**

**ATTEST:**

\_\_\_\_\_  
**Laura Calcote, Interim City Secretary**

**APPROVED AS TO FORM AND LEGALITY:**

\_\_\_\_\_  
**Jennifer Barnes Smith, City Attorney**